

# Ion Beam Deposition of Quantum Dots from Colloidal Solution

and light emitting devices

**Yuki Tani, Satoshi Kobayashi, Hiroshi Kawazoe**  
R&D Center, HOYA Corporation,  
3-3-1 Musashino, Akishima,  
Tokyo 196-8510, Japan



## ABSTRACT

We developed a new technique for fabrications of organic free thin films from a colloidal solutions of surfactant-capped nanocrystalline quantum dots (QDs). This technique provides compatibility between the liquid solution and the vacuum. The CdSe/ZnS QDs ion beam was irradiated onto a substrate in the vacuum chamber. The energy spectra of quantum dots ion beam were measured. We discuss an appropriate conditions for an effective deposition in terms of ion energy. The ion energy provided from a free jet accelerator setup was set at 6 keV, or 0.25 eV/atom. A cross-sectional TEM image of the deposited film shows that the QDs are densely packed in a polycrystalline thin film configuration. A photoluminescence (PL) collected from the deposited film evidences that the deposited QDs are preserved. Soft-landing of the QDs and surface passivation are simultaneously satisfied.

Colloidal quantum dot  
Organic free thin films  
Electroluminescent devices

Electrospray ionization  
Free jet acceleration  
Ion beam technique

## Concept of method

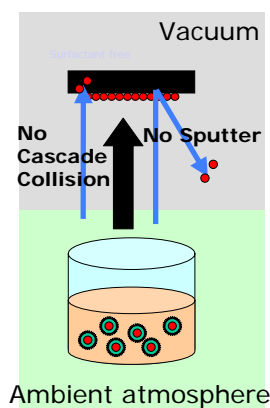

- QDs in liquid solution are deposited on the substrate in Vacuum.
- Solvent and Surfactant are removed.
- QDs are not bounce back, don't cause cascade collision.

## Energy spectrum

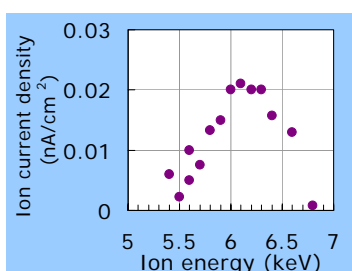

- The energy of 6 keV, corresponds to a mass-charge ratio of  $2.0 \times 10^6$  (amu/e) at the calculated speed 760 m/s.
- 0.25-0.3 eV per atom (CdSe).

The energy distribution of the ions was experimentally measured by an energy analyzer.

## Morphology



- Substrate temp.: 150 C
- QD core diameter: 2.4nm
- Dep. rate: 1-5 nm/min

Smooth planar morphology with a dense polycrystalline structure (TEM).

## Deposition

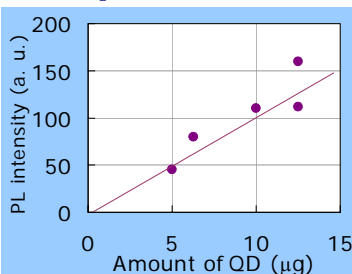

- PL intensity increases with deposition time.
- The film was grown sequentially with soft-landing

Amount of QD = Concentration x Deposition time

## Colloidal quantum dot

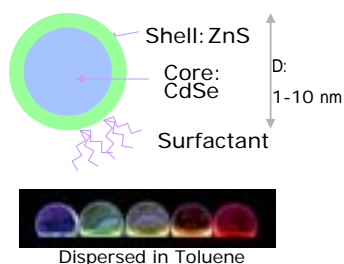

- Narrow emission spectra
- Color tunability by controlling the size & High efficiency
- Commercially available

## Scheme of apparatus Ion beam technique

LIQUID Liquid-dispersed quantum-dots ion-beam deposition apparatus

Jpn. J. Appl. Phys. 46 (2007) L392

**Energy analyzer** is parallel planar electrostatic type. One has two 5mm aperture and is grounded, while the other is biased to a positive potential. The positive ion beam enter the space and is deflected by parallel field.

**Lens** is a beam collimator as einzel lens system.

**Vacuum chamber** and the atmospheric region are connected through three aperture. First and second orifice are conical nozzle shaped.

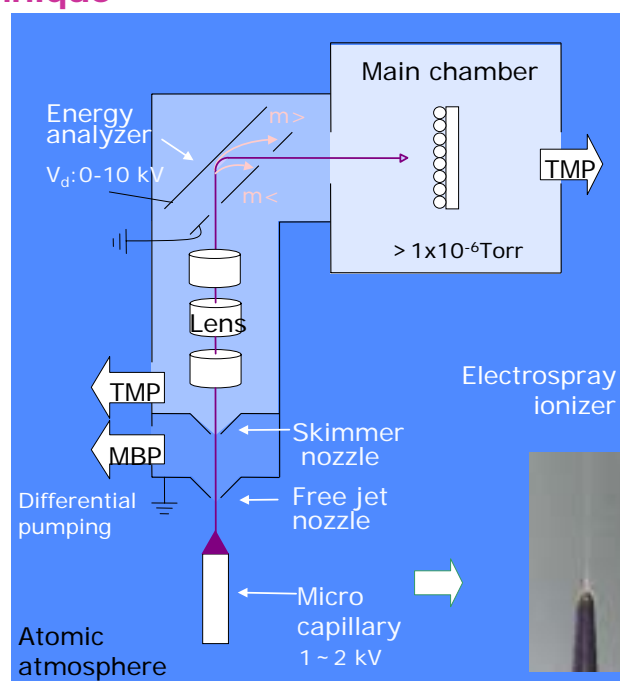

**Super sonic jet emitter** is consist of a differential pumping system and two conical nozzles: free jet nozzle (D:0.5mm) and skimmer nozzle (D:0.7mm).

The gas and ions expand from atmospheric pressure to the vacuum through free jet nozzle as an adiabatic expansion.

**Electrospray ionizer** is consist of a syringe pump, a syringe, a PTFE tube, a stainless steel microcapillary (outer D: 50µm).

The source solution is fed into the capillary and ions are formed by electro-spray.

## Photoluminescence

Measured at room temperature

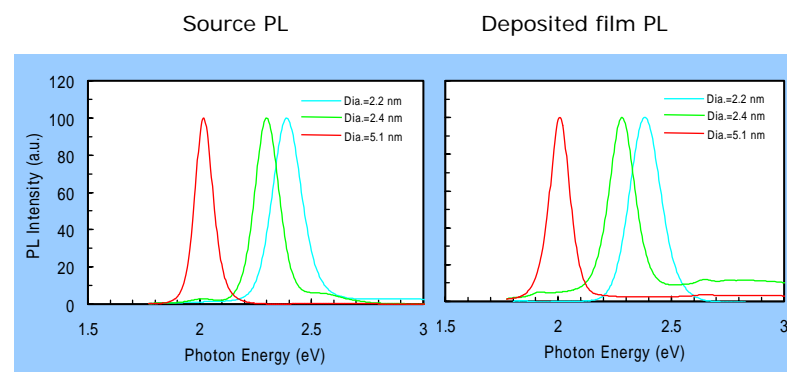

• Film PL were identical to corresponding source.

• The QDs in solution were deposited on the substrate in vacuum chamber without quenching luminescent property

## CONCLUSION

• The CdSe/ZnS nanocrystalline configuration and its optical functions are preserved in the films deposited by our IBD technique (LIQUID process).

• The film thickness of the QDs can be controlled by the deposition time with the beam energy controlled for the soft-landing.

• LIQUID is capable to fabricate QD light emitting devices connecting with the high vacuum deposition process.

## Application

Quantum dot electroluminescent devices

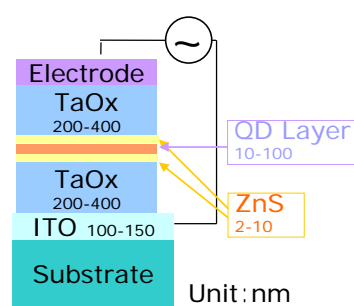

Structure

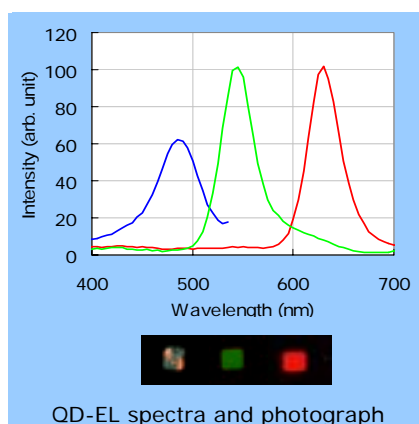

- We fabricated Quantum Dots (QD) light emitting devices from colloidal QD (CdSe/ZnS) solutions.
- ELs show saturated red and green color.
- AC drive (100V<sub>p-p</sub>), Room temperature, 100kHz

The speed of ions and a paraxial portion of the free jet jet are calculated 760 m/s by following equations.

$$V = M \sqrt{\frac{\gamma R T_0}{W} \left(1 + \frac{\gamma - 1}{2} M^2\right)^{-1/2}}$$

$$M = A(\gamma) \left[\frac{x}{D}\right]^{\gamma-1} - \frac{\gamma+1}{2(\gamma-1)} / A(\gamma) \left[\frac{x}{D}\right]^{\gamma-1}$$

V: mean velocity  
M: mach number  
 $\gamma$  (Cp/Cv)  $\gamma = 7/5$  for air  
R: universal gas constant  
W: molar average molecular weight of the air,  $2.9 \times 10^{-2}$  kg/mol  
x: distance between free jet nozzle and skimmer nozzle 3mm  
D: diameter of jet nozzle 0.5mm